

HS HOME PRESSURE SYSTEM WITH Torrium2®

Model Numbers: HS50-06T & HS60-08T

DEPEND ON
DAVEY

WATER PRODUCTS



HS PRESSURE SYSTEM

PRODUCT DESCRIPTION

Robust & compact, four stage, centrifugal pump with Torrium2® constant flow control and loss of prime device for automatic water pressure.

Designed for medium to large size, single and multi-storey homes.

APPLICATIONS

Ideal for pumping clean, non-volatile liquids without fibres or solids in such applications as :-

- Household water supply
- Irrigation
- Water transfer
- Washing systems
- Pressure boosting

FEATURES & BENEFITS

SYSTEM

The HS Pressure System consists of a HS pump fitted with a Torrium2® controller. The Torrium2® is supplied connected electrically to the HS pump motor for:

- Easy non-tradesmen installation and assembly
- Positive safety under varied weather conditions

The combination of the high pressures supplied by the multistage HS pump and constant flow control provided by the Torrium2® enables consumers to enjoy the benefits of a strong comfortable shower from a pump that does not cycle plus the reliability of adaptive technology.

The complete HS Pressure System is compact and quiet providing for:

- Easy installation, especially where space is at a premium
- Non-intrusive operation, for consumer enjoyment

All parts of the entire system that are in contact with the water are manufactured from safe, corrosion resistant materials for:

- Consumer confidence that their water supply will be as good coming out as it was going into the system
- Ability to use the HS pressure system on a variety of water qualities

Compliance with the strict requirements of ISO 9001.2000 quality standards ensures consistency of quality of the system.

OPERATING LIMITS

Maximum system pressure*	700kPa
Capacities to	110 lpm
Maximum total head	50m
Maximum suction head	6m
Maximum ambient temperature	50°C
Maximum water temperature	50°C
Minimum water temperature	1°C

Torrium2® cut-in pressure is normally 80% of the pumps last shut-off head.

*Note: See high pressure operation note on page 4.

TECHNICAL SPECIFICATIONS

FIXED SPEED CASCADING CONTROL OPTION

PUMP

High efficiency, quiet "half blind" impeller in 4 stage design in two flow rate ranges for :-

- More pressure in home outlets
- Choice of performance options to suit most homes
- Quieter household environment
- Improved waterway clearances to reduce impeller blockages

Impeller have dual shaft flats for positive drive and long life, especially important for household pressure systems where pumps are required to stop and start many time during their life.

Patented floating impeller neck rings help improve efficiency and reduce hydraulic noise providing better performance with less noise.

304 stainless steel casing, pump shaft and diffuser baffle returns provide long life and ability to withstand pressure variations.

In-built & removable inlet check valve provides:

- Convenience on installation and easier servicing
- Low pressure loss with fast effective valve closing

Special in-built air purging valve helps remove air from the pump and suction during original priming and also during normal operation, thus:-

- Makes original installation quicker and easier
- Reduces the chance of pump operating in a partial prime condition.

High quality, low-drag mechanical shaft seal for long life and reliable starting.

MOTOR

The Davey manufactured TEFC motor has an IP55 enclosure providing:-

- Excellent corrosion resistance
- High levels of resistance to dust and rain

All HS pump motors are class F insulation rating and have higher than normal ambient temperature ratings of 50°C, providing for longer life, improved tolerance to voltage variations and peace of mind, even on the hottest days.

All HS pump motors are single phase permanently split capacitor design for:-

- Reliable starting even in low voltage circumstances
- Superior frequent starting performance

Single phase motors are protected against both high operating temperatures and high current by a built in, automatically resetting thermal overload.

Double contact C3-HTG sealed bearings for quieter running and longer life.

Corrosion resistant feet on motor shell, include three point bolt-down facility.

Standard models are 220/240 volt, 50Hz, single phase. HS models in 60Hz 110/115 volt and 220/230 volt single phase available on request.

Torrium2® CONTROLLER

Torrium2® starts pump on pressure drop and stops pump on low flow (~1 lpm), thus reducing pump cycling providing constant and even water pressure.

Torrium2® measures the pump shut off head each time the pump stops, and sets the cut-in pressure at 80% of shut-off head, so that the consumer is unlikely to notice any pressure change when the pump is switched on. Torrium2® adapts each time the pump stops, thus allowing the system to accommodate variations in pump performance or site conditions.

Torrium2® has a simple indicator and fault LED system. Red means that the system is in standby. Green means the pump is running.

Torrium2® stops the pump in "loss of prime" circumstances and activates the amber or fault LED indicator:-

- Protecting the pump from dry run damage

When the Torrium2® detects "loss of prime" it waits 5 minutes then goes into auto retry mode, whereby it will restart the pump to see if prime can be re-established automatically. Auto retry occurs at 5 minutes, 30 minutes, 1 hour, 2, 4, 8, 16 and 32 hours. Torrium2® will also retry if it detects flow through the system (eg from mains water pressure returning).

If Torrium2® detects excessive electrical current, such as when a the pump motor is subjected to locked rotor or when someone tries to manually override the Torrium2® by holding in the prime button, the Torrium2® will shut the pump down and indicate fault.

Water over-temperature cut-out fail safe protection, provides a second level of protection against loss of prime and / or closed head operation and / or repetitive cycling for added security and longer life. In the event of the Torrium2® detecting water over-temperature above 70°C it will shut the pump down and the amber LED will be lit. Once the water temperature has dropped to below 60°C, the Torrium2® will allow the pump to restart.

In the event of extremely low flows, Torrium2® will delay starting till the system pressure drops below 80% of last shut-off head. In any case pump

start will occur immediately if either the approximate discharge flow from the systems exceeds 0.5 lpm or the system pressure drops to 50% of the last shut-off head. This start procedure occurs every time overcome pump cycling and improve consumer satisfaction with the system.

Torrium2® has no moving control parts in the waterways:-

- No parts to jam means improved reliability
- Reduction in wasted energy due to pressure loss through the controller performance
- Reliable usage with varying water quality

Corrosion and scale resistant flow and pressure sensors mounted on a high grade stainless steel plate. Special anti scaling electronic functions allow Torrium2® to be used with water of varying quality.

Torrium2® has an in-built spring loaded pressure tank, overcoming the need for regular pressure vessel air charging and checking.

To indicate system pressure changes, Torrium2® is equipped with a pressure indicator window on the side of the inbuilt pressure vessel. If the pressure is low the window will show mainly red. If the pressure is at maximum (i.e. 450kPa for TT45 and 700kPa for TT70 models) the window will show mainly green. The window can also help analyse the occurrence of unwanted leaks. If the colour band in the window is moving towards red, this shows that pressure is decreasing. If the colour band in the window is moving towards green, this shows that pressure is increasing.

Right angle discharge rotatable around full 360°, with optional vertical outlet or pressure tank mounting position on top, facilitates:-

- Easier installation and connection to plumbing
- Use with a choice of optional pressure tank sizes

Comes complete with 2 metre long power lead fitted with an Australian three pin plug for easy installation.

The Torrium2® controller has a metal oxide varistor (MOV) fitted to help protect its circuit from electrical surges. This device is sacrificial and may eventually be destroyed by repeat or high powered surges. To allow you to check the status of the inbuilt MOV in the Torrium2® there is a viewing window at the back of the Torrium2® above the power lead entry / exit grommet. The MOV is the blue disc shaped component. Should it be consumed due to power spikes it will almost always blacken the viewing port. This will indicate a non-warrantable failure.

TECHNICAL SPECIFICATIONS

MATERIALS OF CONSTRUCTION

PART	MATERIAL
PUMP	
Impellers	Glass filled polycarbonate
Lock nut	304 stainless steel
Pump casing	304 stainless steel
Pump backplate	304 stainless steel
Pump shaft	303 stainless steel
Neck rings	Polypropylene + teflon
Seal ring (stationary)	Ceramic
Seal ring (rotating)	Carbon (synthetic)
Seal spring	304 stainless steel
Orings	Nitrile rubber
Stage body	Glass filled noryl
Suction check valve	
Body	Polypropylene
Spring	304 stainless steel
Seal	Nitrile
Priming plug	Glass filled noryl
Motor shell	Marine grade aluminium
Lantern/DE endshield	Marine grade aluminium
Shell & lantern finish	Baked polyester
Torium2®	
Housing	Glass fibre reinforced nylon
Pressure tank diaphragm	Santoprene 87
Pressure tank springs	Molybond coated tempered steel
Sensor plate	316 Stainless Steel
Inlet union	Glass fibre reinforced nylon
Orings	Nitrile

HYDRAULIC PERFORMANCE

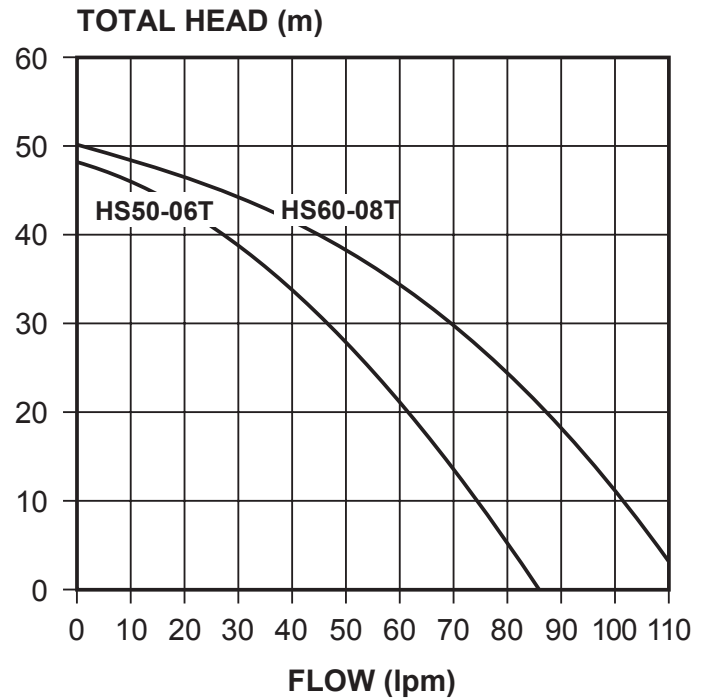

ELECTRICAL DATA

	HS50-06T	HS60-08T
Supply Voltage	220-240V ±6%	
Supply frequency	50Hz	
Phase	Single	
Speed	2850rpm	
Full load current	3.8A	4.9A
Locked rotor current	12.0A	18.0A
Input power (P ₁)	0.89kW	1.1kW
Output power (P ₂)	0.6kW	0.76kW
Enclosure class	IP55	
Insulation class	Class F	
Starting	P.S.C.	

Note: All performance at 240V 50Hz

	Torium2®
Voltage	110V-240V±10%
Phase	Single
Hz	50 / 60
IP rating	56
Maximum load current	10A
Maximum motor size*	1.8kW
Surge protection	Varistor

*At 240V input

INSTALLATION & PRIMING

- Installations with suction lift require a good quality foot valve to avoid loss of prime - remove in-built check valve.
- To prime, fill pump body and suction line through priming plug hole located above suction inlet and replace plug.

TECHNICAL SPECIFICATIONS

DIMENSIONS

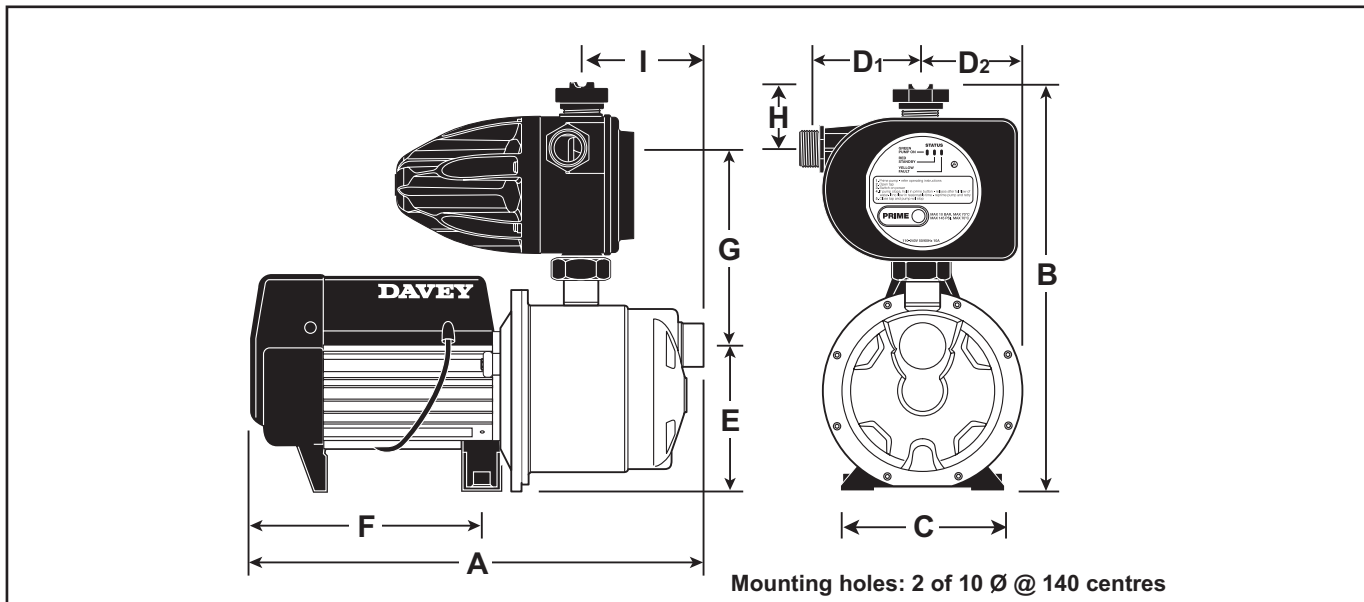

Mounting holes: 2 of 10 Ø @ 140 centres

Model	A	B	C	D ₁	D ₂	E	F	G	H	I	Inlet	Outlet	Net Weight (kg)
HS50-06T	405	390	170	115	105	145	183	170	75	125	1 1/4" F	1" M	9.8
HS60-08T	430	390	170	115	105	145	208	170	75	125	1 1/4" F	1" M	11.3

All dimensions in mm unless otherwise stated.

HIGH PRESSURE INSTALLATION AND NOTES

HS pressure systems are intended to source water from wells, tanks, creeks, rivers or other low pressure water supplies. In some cases, HS pumps may be required to be installed taking water directly from mains or municipal water sources.

In such circumstances all applicable local plumbing code requirements must be followed.

In addition the following limits apply to the HS system:-

- For TOTAL system pressures of 820 kPa, the standard HS system with or without Supercell 8P or 18P may be used provided the pump is fitted with a Davey HS High Pressure Booster Kit (p/no. 31930).

For further details consult the HS Installation & Operating Instructions and Product Update Bulletin UW94.

DEPEND ON
DAVEY

WATER PRODUCTS

Davey Water Products Pty Ltd
Member of the GUD Group
ABN 18 066 327 517

AUSTRALIA
Head Office and Manufacturing
6 Lakeview Drive,
Scoresby, Australia 3179
Ph: +61 3 9730 9222
Fax: +61 3 9753 4100
Website: davey.com.au

Davey Support Centre
Ph: 1300 369 100
Fax: 1300 369 119
E-mail: sales@davey.com.au

NEW ZEALAND
7 Rockridge Avenue,
Penrose, Auckland 1061
Ph: +64 9 570 9135
Fax: +64 9 527 7654
E-mail: sales@daveynz.co.nz
Website: daveynz.co.nz

Davey Support Centre
Ph: 0800 654 333

REST OF WORLD
6 Lakeview Drive,
Scoresby, Australia 3179
Ph: +61 3 9730 9121
Fax: +61 3 9753 4248
E-mail: export@davey.com.au
Website: davey.com.au



DWP0100/0412 supersedes D984-1/7.5K/0810/IPM

This literature is not a complete guide to product usage. Further information is available from your Davey dealer, Davey Support Centre and from the relevant product Installation and Operating Instructions. This data sheet must be read in conjunction with the relevant product Installation and Operating Instructions and all applicable statutory requirements. Product specifications may change without notice.

© Davey and Torrium are registered trademarks of Davey Water Products Pty Ltd. © Davey Water Products Pty Ltd 2012.