

F60 DIGITAL PUMP CONTROLLER

THE ULTIMATE IN VERSATILE & FLEXIBLE PUMP CONTROL

SIMPLE TO USE AND VERY POWERFUL



FEATURES

- Very simple to program
- Multi voltage operation
- Displays pressure and set points
- 15 Programmable timers built in
- Powerful 40 Amp solid state drive
- Dedicated 16 Amp alarm relay
- Detachable electrical housing
- 20 Bar 290 psi Pressure rating
- Suits pipes 25mm (1") & Larger
- Accepts remote input
- IP67 Rated

FURTHER INFORMATION

Further information including installation guides, programming guides and videos can be found at the following web page: <http://www.kelco.com.au/f60-pump-controller>

OUTLINE

The F60 Digital pump controller monitors system pressure and flow to ensure complete pump protection. It can be set to operate in one of four unique modes, each with a wide range of functions.

ORDERING

The F60 Digital Pump Controller is available in all thermoplastic construction with a 1" BSP process connection. The standard controller can operate from 220 ~ 240 VAC or from 24 VAC or DC. A dedicated 12 VDC model is also available.

Model Number	Description
F60	Standard model for 220 ~ 240 VAC and 24V AC or 24V DC operation.
F60-12	Low voltage model for 12V DC operation only.

TECHNICAL DATA

DIMENSIONS

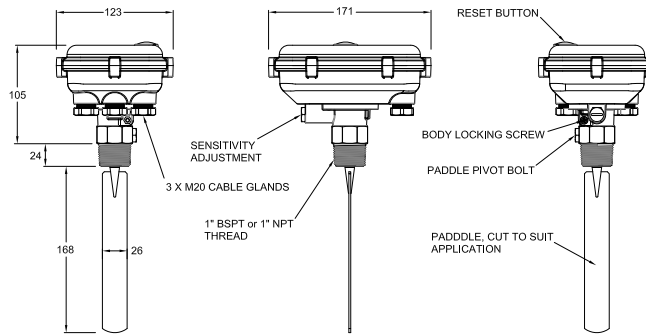

FUNCTIONS

The F60 Digital Pump Controller includes 15 unique functions and 4 operating modes. The table below sets out the functions and the modes they operate under.

MODES OF OPERATION	1	2	3	4
Functions (# Settable)				
# Select pressure units kPa or psi	Y	Y	Y	Y
# Pre-start delay timer.	Y	Y	Y	Y
# Start-up timer	Y	Y	Y	Y
# Pressure Timer (Allows time for the pressure to rise)				Y
# Run-on timer	Y	Y	Y	Y
# Pressure dip timer				Y
# Delayed restarting timer	Y	Y	Y	Y
# Starting pressure		Y	Y	
# Stopping pressure			Y	Y
# Cyclic running and stopping timers	Y	Y	Y	Y
# Auto restart if run dry. Single or repeatable tries		Y	Y	Y
# Anti-cycling	Y	Y	Y	
# Burst pipe detection	Y	Y	Y	
# Leak detector			Y	
# Program Lock	Y	Y	Y	Y
# Starts the pump at a preset low pressure		Y	Y	
# Stops the pump at a preset high pressure			Y	Y
Stops the pump if flow stops	Y	Y	Y	Y
Displays the system pressure in preferred units	Y	Y	Y	Y
Displays the high & low pressure set points			Y	Y
Can start the pump using an external switch	Y	Y	Y	Y
Starts & stops the pump on flow regardless of pressure	Y			
Displays the total time the pump ran in minutes				Y
On a fault, displays the reason the pump was shut down	Y	Y	Y	Y
Remote stop via an external switch opening its contacts	Y	Y	Y	Y
Stops the pump if flow stops.	Y	Y	Y	Y
Loss of prime protection for the pump.	Y	Y	Y	Y

FEATURES

Operating Range	
Ambient Temperature Range.	1°C to 50°C
Liquid Temperature Range.	1°C to 60°C
Ingress Protection Rating.	IP67
Pre-Start Delay Timer. (In all modes)	Adjustable from 1 second to 18 hours in 1 second increments.
Start-up Timer. (In all modes)	Adjustable from 1 second to 4 minutes in 1 second increments.
Pressure Rise Timer (In mode 4 only)	Adjustable from 1 second to 15 minutes in 1 second increments.
Run-on Timer. (In all modes)	Adjustable from 1 second to 15 minutes in 1 second increments.
Pressure Dip Timer (In mode 4 only)	Adjustable from 1 second to 4 minutes in 1 second increments.
Delayed Restarting. (In modes 1 to 3 only)	Adjustable from 1 minute to 99 hours 59 minutes in 1 minute increments.
Cyclic Running & Stopping. (In all modes)	Running and stopping times both adjustable from 2 minutes to 99 hours 59 minutes in 1 minute increments.
Auto Restart if Run Dry (In all modes)	Adjustable from 1 minute to 99 hours 59 minutes in 1 minute increments.
Anti Cycling. (In modes 1 to 3 only)	Adjustable from 1 motor start per hour to 1800 motor starts per hour.
Burst Pipe Detector. (In mode 3 only)	Adjustable from 1 minute to 99 hours 59 minutes in 1 minute increments.
Maximum Operating Pressure Static or Dynamic.	20 Bars 290 psi
Minimum Burst Pressure.	> 30 Bars 435 psi
Starting Pressure Range.	0 to 2000 kPa or 0 to 290 psi in steps of 1 kPa or 1 psi
Stopping Pressure Range.	0 to 2000 kPa or 0 to 290 psi in steps of 1 kPa or 1 psi
Minimum Pressure Differential On to Off and Off to On.	1 kPa or 1 psi.
Recommended Pipe Size.	25 mm 1" or larger. (There is no upper limit)

SERVICEABILITY

The F60 digital pump controller is not user serviceable. However, spare parts and paddles are available from Kelco Engineering or from your distributor.

3 PHASE PUMPING SYSTEMS

The F60 can be used to control both single and 3-phase pumps provided a 220~240 VAC or 24VAC supply is available at the installation site.

ELECTRICAL

Supply Voltage Standard Model	220 to 250 VAC or 18 to 25 VAC or DC (Multi Voltage Input)
Supply Voltage 12V DC Model	11 to 14 VDC
Maximum Motor Load all Models	Single phase motors up to 2.4kW maximum at 240VAC (P1). Three phase motors of all sizes via a suitable interposing contactor, no maximum motor size applies.
Relay 1 Contact Rating	16 Amps at 240 VAC resistive
Relay 2 Contact Rating	16 Amps at 240 VAC resistive

KELCO Engineering Pty Ltd

ABN 20 002 834 844 **Head office and factory:** 9/9 Powells Road Brookvale NSW 2100 Australia. **Postal Address:** PO Box 7485 Warringah Mall Post Shop Brookvale NSW 2100 Australia. **Phone:** +61 2 9905 6425 **Fax:** +61 2 9905 6420 **Email:** Sales@kelco.com.au **Web:** www.Kelco.com.au

PLEASE NOTE: Kelco Engineering Pty Ltd reserves the right to change the specification of this product without notice. Kelco Engineering Pty Ltd accepts no liability for personal injury or economic loss as a consequence of the use of this product. All rights reserved copyright Kelco Engineering Pty Ltd © 2014 The Kelco F60 Pump Controller is protected by a 12 month return to base warranty. Full details of our warranty can be downloaded from: <http://www.kelco.com.au/warranty>