

F30 PUMP CONTROLLER

A VERSATILE PUMP CONTROLLER THAT INTEGRATES FLOW AND PRESSURE. THE F30 BRINGS THE ADVANTAGES OF CONSTANT FLOW AND DRY RUN PROTECTION TO TRADITIONAL PRESSURE SYSTEMS

DESCRIPTION

The F30 Pump Controller is a digital electronic flow switch that monitors both flow and pressure. When included in a pressure system the F30 vastly improves overall performance and gives the benefit of both constant flow and dry run protection. Pressure systems normally use pumps with steeply varying pressures, not because this gives the user any advantage but simply because a high differential pressure is required to operate the pressure switch that normally controls such pumps. The user sees the effect as fluctuations in pressure at the tap. If loss of prime occurs a pump controlled by a pressure switch will run dry and invariably sustain damage.

THE F30 PUMP CONTROLLER

The F30 Pump Controller offers a far better approach. The pump starts on flow as soon as there is a modest demand. When demand ceases the F30 continues to run the pump for a settable length of time sufficient to recharge the system's air cell. Such a system allows the selection of a pump that has a flat curve and delivers a steady constant pressure over widely varying flows. An air cell with a very small draw off can be used in such a system. There only has to be sufficient stored pressure to re-actuate the F30 controller the next time there is a demand. With the F30 system the external pressure switch is set to start the pump at a pressure only slightly higher than the system's static pressure. If the demand is too low to actuate the F30's paddle, or if for any reason the pressure falls, eventually the pressure switch will close and signal the F30 to start the pump. The F30 then runs the pump for a preset time, recharges the air cell, switches off the pump and reverts to standby mode.

DRY RUN PROTECTION

A pump running under the control of an F30 will start if the pressure drops or if a tap is turned on. If the system subsequently runs out of water the F30 senses the loss of flow and the lack of pressure and immediately stops the pump. A red warning light on the controller then flashes rapidly to indicate there is a problem. The pump will not restart until the power to the F30 is turned off and back on. The pump will then run for a settable time and again test the system for pressure and flow. If the pump is still running dry the F30 will again automatically shut it down. If flow has been restored the pump will continue to run until either the flow demand ceases or until the system is fully pressurized.



- Run on Timer Control
- Start up Timer Control
- Pressure switch LED
- Paddle and Alarm LED
- Timer LED



AUSTRALIAN MADE

TECHNICAL DATA

CONSTRUCTION

The F30 controllers have no metal parts in contact with liquids. They operate magnetically through their thermoplastic housings. They are therefore ideally suited to use in aggressive ground water, seawater or chlorinated water and with a huge variety of chemical solutions including most acids and alkalis.

The F30 is made from a blend of ABS and polypropylene thermoplastics, specifically tailored to give the highest possible performance, in terms of mechanical strength, ultraviolet stability, and chemical inertness. All the F30 controllers use our well proven magnetic suspension system, to give both a frictionless spring return action to the paddle, and total isolation of the electronic module. The microprocessor-based electronics built into the F30 have both brown out and over voltage protection built-in.

INSTALLATION

The F30 pump controller can be fitted to any type of pipe, 25mm (1 inch) diameter or larger and should be mounted in a straight section of the pump's discharge pipe, downstream of the air cell. A 1" BSP female thread socket or tee must be provided to fit the controller. To make setting up the system simple, isolation valves and a bleed valve should be fitted to the pump as shown in the accompanying sketch.

TYPICAL INSTALLATION

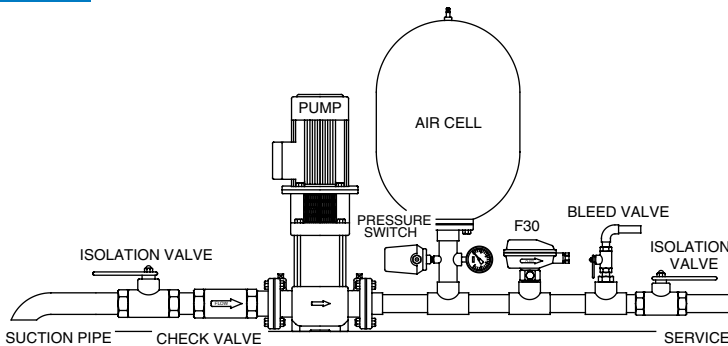

MODELS AVAILABLE

Model	Description
F30-240	Standard all thermoplastic model for mains voltage operation
F30-24	Low voltage all thermoplastic model. For 24VAC operation
F30-12	12VDC model, for engine, battery or solar operation

OPTIONS

- 316 Stainless steel body with 100 Bar pressure rating
- 1"NPT Male process connection

SPECIFICATIONS

- Microprocessor digital control.
- Pressure switch input accepts a single switched active to the AUX terminal.
- Indicator LED shows when the pressure switch is open or closed.
- Fully independent control over both the start-up and run-on timers.
- Start-up timer adjustable from 0 to 180 seconds.
- Run-on timer adjustable from 0 to 300 seconds.
- True paddle status LED, turns on and off in response to flow.
- Power indication LED blinks to indicate the F30 is powered up.
- Timer LED indicates the start-up timer is running.
- Dry run LED flashes to indicate the pump has shut down on loss of flow.
- Timer LED indicates the run-on timer is running.
- Output to pump contactor is via 10Amp (resistive) 240V S.P.D.T. voltage free relay contacts. (One set).
- Brown out and voltage surge protection built-in.
- Magnetic paddle adjustment for flow sensitivity.
- Three M16 cable glands accept 8mm flex, or three M16 conduit connections.
- Maximum operating pressure, static or dynamic, standard models 18 Bars (260 PSI), 316 stainless models 100 Bars (1400 PSI).
- Maximum liquid temperature 80°C.
- Minimum liquid temperature -20°C.
- Liquid Ph 1 to 14.
- Weatherproof rating IP56 (Hose proof).

DIMENSIONS

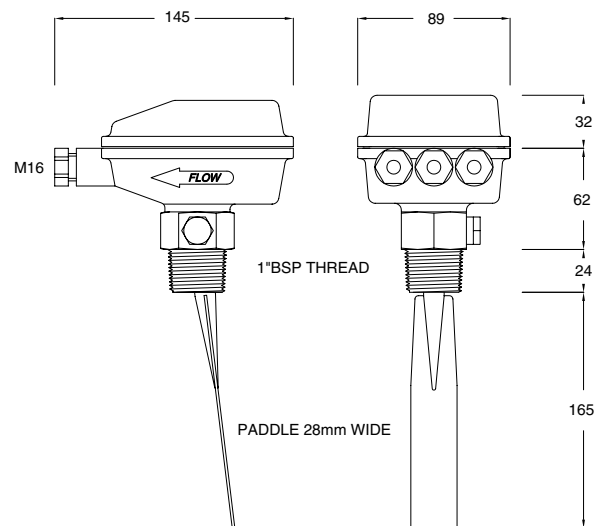

MADE IN AUSTRALIA BY

KELCO ENGINEERING

Division of CYNCARD PTY LTD A.B.N. 20 002 834 844
Head Office and Factory: 9/9 Powells Road BROOKVALE 2100 AUSTRALIA
Postal Address: PO Box 496 BROOKVALE NSW 2100
Phone: 61 2 9905 6425 Fax: 61 2 9905 6420
Email: sales@kelco.com.au URL: www.kelco.com.au

PLEASE NOTE: Cyncard Pty Ltd reserves the right to change the specification of this product without notice. Cyncard Pty Ltd accepts no liability for personal injury or economic loss as a consequence of the use of this product. All rights reserved copyright Cyncard Pty Ltd © 2003

INSTALLATION AND OPERATION OF F27 & F30 PUMP CONTROLLERS

The F27 and F30 pump controllers require both electrical and mechanical fitting. Installation or servicing of these controllers should only be carried out by competent qualified personnel familiar with hydraulics, pump fitting and with electrical control circuitry. All electrical work associated with the F27 and F30 controllers must be carried out by qualified persons only. All wiring must conform to the relevant local codes.

INSTALLATION

A suitable location should be selected for the controller preferably in the discharge pipework of the pump. The controller should be installed in a location that is away from both vibration and heat, preferably out of direct exposure to the weather and above any flood level. A 1" BSP or larger socket must be provided in the pipework to fit the controller. The socket should be located on the topside of a horizontal section of the pipe with at least 5 diameters of straight pipe either side of the controller. Under no circumstances mount the controller under the pipe or close to valves, tees, bends or any other object likely to cause turbulence in the flow.

The accompanying drawing shows an ideal set up with the F27~F30 controller screwed into a 25mm by 40mm reducing bush that in turn is screwed into an Anka quick coupling. The coupling is then screwed into a 40mm pipe tee. A quarter turn twist of the controller allows it to be removed from the pipework without the need to disturb the wiring. Isolation valves should be provided in both the suction and discharge pipes in all installations to allow servicing and setting up of the system. We recommend a small bleed valve be included in the discharge pipe close to the pump and downstream of the controller.

In an F30 installation, dropping pressure to atmosphere through this valve allows the pressure switch to be easily set up and the controller's time delay settings accurately adjusted. By locating a bleed valve downstream of the controller, the flow rate needed for actuation can be simulated and accurately measured. Fine-tuning of the system is then easily accomplished.

socket, as to do so may damage the controller. When properly installed there should be a gap of at least 4mm between the top of the 1" BSP thread and the under edge of the spanner hexagon. Under no circumstances should the thread be allowed to bottom out in its socket as to do so places the thread in tension and may result in the controller housing cracking under pressure.

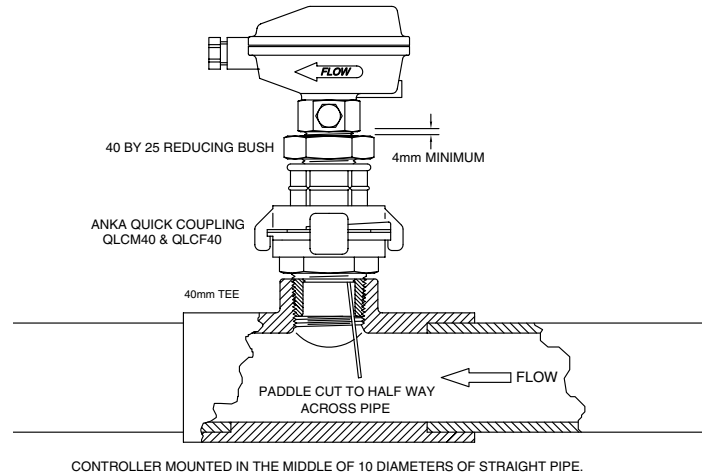

CONTROLLER MOUNTED IN THE MIDDLE OF 10 DIAMETERS OF STRAIGHT PIPE.

IDEAL INSTALLATION OF A CONTROLLER

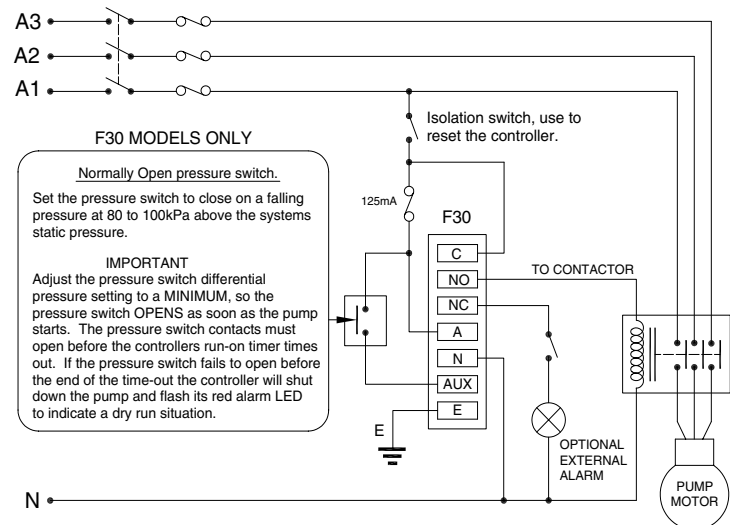

TYPICAL 3-PHASE WIRING DIAGRAM

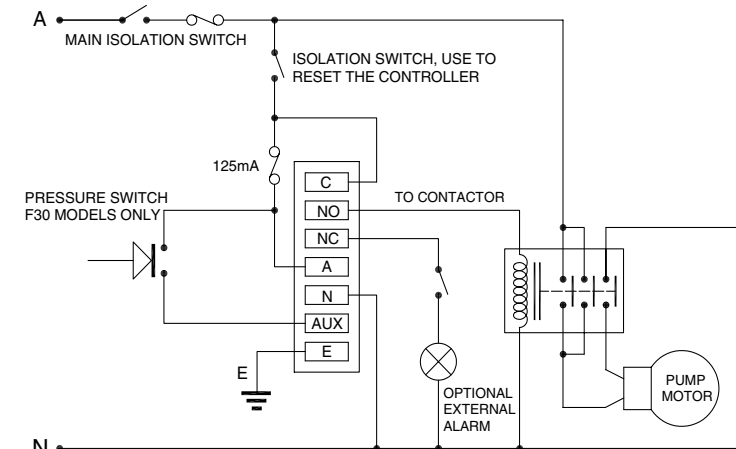

TYPICAL SINGLE PHASE WIRING DIAGRAM

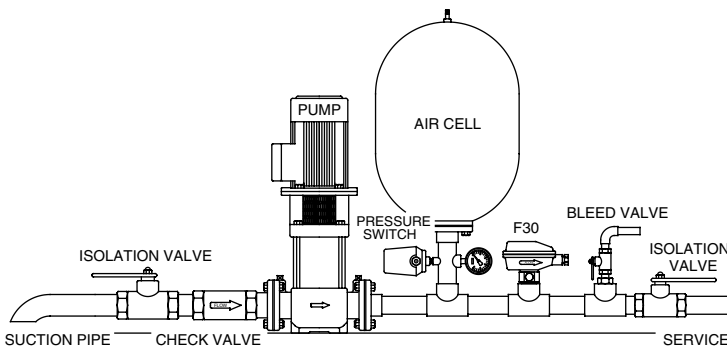

TYPICAL INSTALLATION WITH AN F30 CONTROLLING A VERTICAL MULTISTAGE PUMP.

In most installations the paddle of the controller will need to be trimmed to suit the specific pipe in which the unit is to be installed. The paddle of the controller needs a force of 15 to 20 grams acting on it from the flow in order to operate correctly. High velocity flow can generate high forces and damage or break the paddle. As a general guide the paddle should only extend to the centre line of the pipe, or a bit past the centre. The paddle would not normally be left longer than this unless the flow velocity will be very low. The paddle can be trimmed in both length and width if required. Apply Teflon tape or a suitable thread sealant and screw the controller into the socket using the spanner flats provided. Do not twist the body of the controller or use it to screw the unit into the

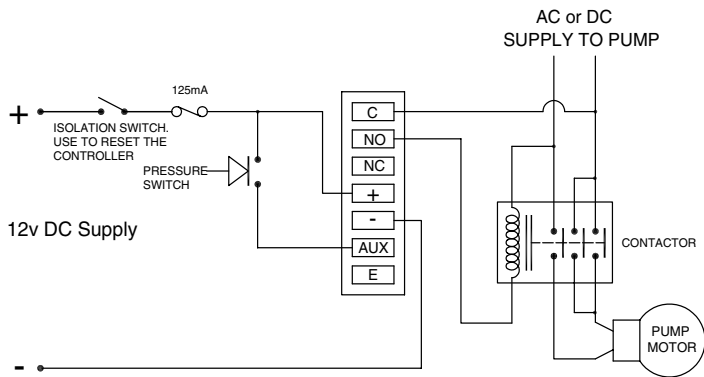

F30 12V DC WIRING DIAGRAM

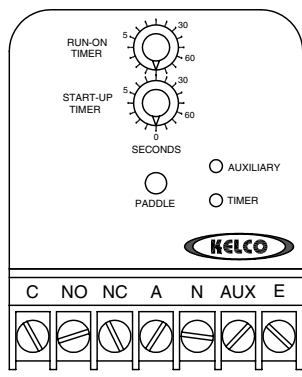

LAYOUT OF THE CONTROLS AND INDICATOR LIGHTS

RUN-ON TIMER
THE RUN-ON TIMER SETS HOW LONG THE PUMP RUNS ON AFTER FLOW STOPS. ON THE F30 IT ALSO SETS HOW LONG THE PUMP RUNS AFTER THE PRESSURE SWITCH CLOSES. IT IS ADJUSTABLE FROM 1 SECOND TO 5 MINUTES.

START-UP TIMER
THE START-UP TIMER IS ADJUSTABLE FROM 1 SECOND TO 3 MINUTES AND IS USED TO GET THE PUMP STARTED IN SPIRE OF NO FLOW.

AUXILIARY
ONLY ON THE F30, THIS LIGHT TURNS ON WHENEVER THE PRESSURE SWITCH CONTACTS CLOSE.

TIMER
THIS LIGHT TURNS GREEN WHEN THE START-UP TIMER IS RUNNING AND TURNS RED WHEN THE RUN-ON TIMER IS RUNNING

PADDLE
THIS LIGHT INDICATES THE TRUE POSITION OF THE PADDLE. IT TURNS GREEN WHENEVER THE PADDLE IS ON. ON THE F30 IT ALSO FLASHES RAPIDLY RED TO INDICATE IF THE PUMP HAS RUN DRY. IT BLINKS SLOWLY RED IN STANDBY MODE WHENEVER THE POWER IS ON.

ELECTRICAL

The F27 and F30 controllers require a continuous stable supply to their Active terminals. In most installations they will also need an isolation switch to allow them to be reset. To protect the controllers a 125mA fast blowing fuse should be placed in series with the supply active. All controllers are protected from over voltage by high amperage varistors that will blow the control circuit fuse in the event of a voltage surge beyond the maximum limits set out in the table below. Where possible ensure the control circuit is not on the same phase as the pump motor. This is particularly important where long cable runs are involved. Voltage drop from the pump motor starting may cause the controller to reset, or its output relay to chatter and cause the pump to jog. Jogging can snap a pump shaft very quickly, so please take all precautions to ensure the supply to the controller is stable and adequate for the job. Supply voltage must be within the limits set out in the table below.

SUPPLY VOLTAGE

MODEL	MAXIMUM SUPPLY VOLTAGE	MINIMUM SUPPLY VOLTAGE	SWITCHED SUPPLY TO AUXILIARY
F30-240	260VAC	160VAC	160 to 260VAC
F30-24	28VAC	18VAC	18 to 28VAC
F30-12VDC	15VDC	10VDC	10 to 15VDC
F27-240	260VAC	160VAC	160 to 260VAC
F27-24	28VAC	18VAC	18 to 28VAC

Note: Current draw with their internal relay energised is <85mA for all F27 and F30 controllers.

All the controllers use an inbuilt relay as their output. The contacts of the relay are voltage free. The relay contacts are rated at 250VAC at 10Amps resistive. To ensure a long reliable life from the controllers we recommend all pump motor control should be via a suitable contactor.

WIRING IN THE PRESSURE SWITCH

The F30 controllers require an input from an external pressure switch located in the discharge pipework of the pump. The F30 accepts a switched input to its AUX terminal that is at the same voltage, and derived from the same phase as the main supply to the F30. The current draw through the pressure switch is <5mA. Series connect the pressure switch contacts between the control circuit active and the AUX terminal. Use only the contacts that close on a falling pressure, that is, the low-pressure cut in contacts. If the switch has dual poles, connect both sets of contacts in parallel to reduce the resistance path through the switch. Details on setting up and adjusting the pressure switch can be found further on.

FUNCTIONS OF THE INDICATOR LIGHTS

PADDLE LIGHT	FUNCTION
Green	Indicates that the paddle is in the on position. Normally off, this light turns green as soon as flow pushes the paddle into the on position. The pump will be on whenever this light is green
Slow Red Pulse	Blinks every two seconds to indicate power is on to the controller. This light will slowly blink red whenever the power is on but the pump is off.
Rapidly Flashing Red	On the F30 controllers only, this light flashes rapidly red indicating that the pump has run dry and the controller has shut down the pump due to lack of pressure. Normally the blue auxiliary light will also be on, indicating that the pressure is too low.

TIMER LIGHT	FUNCTION
Green	Provided the start-up timer is set to some value other than zero, this light indicates that the start-up timer is running, only comes on when the controller is first powered up. The pump will run while ever this light is on.
Red	Indicates that the run-on timer is running. Can only come on after the start-up timer has timed out. Provided the run-on timer is set to some value other than zero, this light will switch on whenever the paddle swings to the off position. On an F30 controller it will also switch on whenever the pressure switch contacts close. The pump should be running while ever this light is on.

F30 CONTROLLERS ONLY

AUXILIARY LIGHT	FUNCTION
Blue	This light indicates the true status of the remote pressure switch. It is on when ever the contacts of the pressure switch are closed. The pressure switch contacts must be open and this light off before the run-on timer times out. If not, the controller will shut down the pump and go into alarm mode and the red paddle light will flash rapidly. The pump will not restart until power to the F30 is reset.

F27 PUMP CONTROLLER

The F27 controller is a conventional 1" BSP paddle flow switch with a built in micro electronic controller that gives a fully adjustable override on start function and an independently adjustable paddle bounce ignore, or run on function. A pump under the control of an F27 can start in spite of no initial flow; it will ignore paddle bounce and can run on for up to 5 minutes after flow stops. The run on function is very useful for pressurising air cells and for pumping down low yield bores.

F30 PUMP CONTROLLER

The F30 pump controller operates in exactly the same way as the F27 but in addition can accept an input from an external pressure switch. The auxiliary input allows the F30 to read both flow and pressure, and means that a pump under its control will start automatically on a pressure drop as well as on a flow demand. By monitoring pressure the F30 can identify a dry run situation and shut down the pump. The F30 is very versatile and can be used in many innovative ways in automatic tank filling systems and in industrial pump control.

TIMER SETTINGS

Time delay adjustment is by means of two 16 position rotary switches. The time delays are individually programmed into the controllers to give the rotary switches the following delays.

TIMER	DELAY IN SECONDS
Start up Timer	0, 1, 2, 3, 4, 5, 10, 15, 20, 25, 30, 40, 50, 60, 120, 180
Run on Timer	0, 1, 2, 3, 4, 5, 10, 15, 20, 25, 30, 40, 50, 60, 180, 300

ADJUSTING TIMER SETTINGS

After adjusting the timer settings, the power to the controller must be reset, that is, it must be turned off for a minimum of 0.5 seconds and then turned on again, before any changes will take effect. This applies to all the controllers under all operating conditions.

BASIC FLOW SWITCH FUNCTION

Both the F27 and F30 pump controllers have two independent timers and are individually adjustable in steps. With both timer dials set to zero, the controllers behave like a basic flow switch and respond solely to paddle movement. On power up, the only indication of activity will be the paddle light slowly blinking red to indicate the power is on. If the paddle is pushed into the on position, the output relay will energise and the paddle light will turn green. If the paddle swings to the off position the output relay de-energises immediately, the pump will stop and the paddle light will revert to slowly blinking red.

OVERRIDE ON START

Set the run-on timer to zero. Set the start-up timer to 5 seconds. Reset the power for the change to take effect. On power up the pump should start. The green timer light will come on and stay on for the 5 seconds. If the paddle is pushed into the on position the main green paddle light will come on. At the end of the time out, the green timer light will go out but if the paddle is on the pump will continue to run. If the paddle then swings to the off position the paddle light will turn off and the pump will stop. The start-up timer should be set to a few seconds longer than the time it takes for the paddle light to come on. By watching the timer and paddle lights on power up, it is a simple matter to correctly set the start-up timer.

RUN-ON TIMER

Set both the start-up and run-on timers to 5 seconds. On power up the pump should start and the green timer light should come on. If the paddle swings into the on position the green paddle light will also come on. After 5 seconds the green timer light will go out but the pump will continue to run and the paddle light will remain green. If the paddle then swings to the off position the green paddle light will go out and the timer light will turn on red indicating the pump is running on the run-on timer. The pump will continue to run while the run-on timer is running. If the paddle swings back to the on position before the run-on timer times out, the pump will continue to run seamlessly. If the paddle fails to return to the on position within the 5 seconds the pump will stop. The run-on timer's red light will go out and the green paddle light will also go out. Every time the paddle swings back to the off position the run-on timer will re-run and keep the pump running while it times out.

SETTING UP THE PRESSURE SWITCH

Set the pressure switch so its low-pressure contacts close on a falling pressure at 8 to 10M head or 80 to 100kPa above the systems static pressure. In a pressurised system with a slow bleed off the pressure switch contacts must close before all the pressure leaches away. In addition, the pressure switches differential setting must be set to a minimum. The object is to have the pressure switch start the pump only and then for its contacts to open as soon as the pressure starts to rise and before the run-on timer times out. If the recommended bleed valve and pressure gauge have been included in the installation the job of adjusting the pressure switch and testing the system is made very simple.

Given that the pressure switch has been correctly adjusted, an F30 will function in the following manner. The paddle light will blink slowly red indicating power is on. If the bleed valve is slightly opened so as not to actuate the paddle then as soon as the pressure reaches the cut in pressure of the pressure switch and its contacts close, the pump starts. The blue pressure switch light and the red run-on timer light will turn on. As the pressure rises, the pressure switch contacts should open, the blue light will go out and the pump will continue to run under the control of the run-on timer. When the run-on timer times out the pump will stop and the red run-on timer light will go out. The paddle light will again blink slowly red. The net effect has been to re-pressurise the system. If the pressure is allowed to leach away again, the process will repeat and then the F30 will return to standby mode.

It is important to note that the pressure switch is only used to start the system, not to stop it as in a conventional pressure system. The result is a constant pressure system not constrained by the need to pump up to a high cut out pressure simply because the pressure switch requires it. A multi stage pump can be de-staged, or a pump with a substantially flat constant flow curve can be selected to operate under the control of the F30. This can result in substantial savings in running costs and in many applications provide a highly useful constant pressure flow, essentially free of the pressure fluctuations that plague conventional pressure systems.

F30 DRY RUN PROTECTION

The first time the system is started, the pressure switch contacts will be closed, due to lack of pressure. When power is applied, the pressure switch will control the start-up timer and not the run-on timer. Only after the initial time out of the start-up timer does the pressure switch control the run-on timer. It is important to understand this, because it means that the start-up timer will need to be set to a value slightly longer than the time it takes for

the pressure switch contacts to open. After this initial startup, and once the system has stabilized, closing of the pressure switch will trigger the run-on timer and not the start-up timer. In normal operation, if the pressure falls and the pressure switch contacts close, it will be the run-on timer that determines the time the pump runs for. During the initial start up, if the start-up timer times out before the pressure switch contacts open the controller will go into alarm mode and the pump will stop.

The same effect will occur when recovering from a dry run lock out situation. That is, with the system in alarm mode, resetting the power will start the pump, but it will be the start-up timer that the pressure switch is controlling and not the run-on timer. Only after the initial time out of the start-up times will the system get back into its normal mode where subsequent closing of the pressure switch triggers the run-on timer.

The start up timer needs to be set to a value that lets the pressure rise sufficiently to open the pressure switch contacts. It doesn't need to be sufficient time to fully pressurize the system, just enough to get it started. Subsequent closing of the pressures switch will trigger the run-on timer and it is its longer cycle that will fully charge the system.

The F30 will start a pump on a falling pressure, and it expects to see the pressure rise as soon as the pump starts. At any time, during normal running or during standby, the closing of the pressure switch contacts will start the run-on timer running. If the run-on timer times out and the pressure switch contacts have not opened, the F30 will go into alarm mode. The pump will stop and the paddle light will turn red and flash rapidly. In alarm mode the paddle is overridden and even if it is jammed in the on position the pump will not run. Normally in this situation, the blue pressure switch light will also be on, indicating that the pressure switch is closed and therefore the pressure is too low.

To restart the pump, turn the power off wait half a second and turn it back on. If the pump is running dry, the F30 will again time out on its main timer, stop the pump and go back into alarm mode. With the pump primed, reset the power and observe the blue pressure switch light. As the pressure rises the blue light will go out and the pump will continue to run under the control of the main timer. When the timer times out the pump will stop and the paddle light will revert to slowly blinking red, indicating all is well and the controller is in standby mode. If the recommended isolation and bleed valves have been included in the installation the dry run protection system can be tested by opening the bleed valve and shutting off the pump suction isolation valve while the pump is running.

SENSITIVITY ADJUSTMENT

A sensitivity adjusting screw is provided for fine-tuning the controllers. Under the end of the controllers housing is a hex headed plug that covers the adjusting screw. Remove the plug and using a broad bladed screwdriver wind the adjusting screw anticlockwise to increase the sensitivity (reduce the flow rate needed to actuate the paddle.) As supplied the screw is wound fully in, and the controller set to its least sensitive.

The maximum sensitivity is reached with the screw wound out to a point where the hex dust cover can still be refitted. Normally the sensitivity screw should be left fully in. If the paddle has been trimmed too short, the effect can be compensated for by winding the sensitivity screw out a few turns.

HOW TO CONTROL A LOW YIELD TANK FILLING BORE PUMP

An F30 pump controller can be used in many novel ways to control a pump. The schematic below shows how to use a single external timer to restart a borehole pump that has dropped out on loss of prime, due to low yield or high draw down.

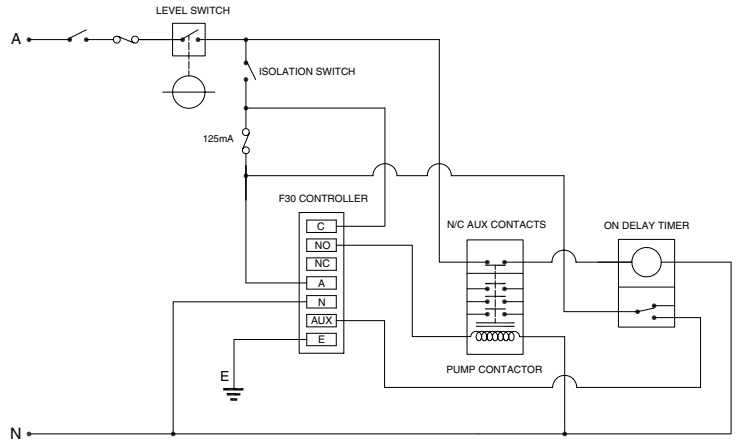

AUTO RESTART OF A TANK FILLING SUBMERSIBLE BORE PUMP

A single external timer can be used to control the AUX terminal of an F30 that in turn restarts a pump after any required time delay. With reference to the accompanying schematic, when the tank level switch closes it powers up the F30 and immediately energises the pump contactor, and starts the pump. The Normally Closed auxiliary terminals of the contactor will open, so there will be no power to the external timer. If the F30 drops the contactor out because of lack of flow, the contactors auxiliary terminals will close and power up the external timer. The timer will run for whatever it is set to, say 2 hours, before its contacts close and power up the auxiliary terminal of the F30, restarting the F30 and the bore pump. As soon as the pump starts, power is lost to the external timer and its contacts open, dropping the power off the F30 auxiliary terminal. The bore pump runs on under the control of the F30. If the bore draws down again, the process will repeat with the pump restarting at whatever time interval has been set on the external timer. If the bore is still dry when the external timer powers up, the pump will only run for the time set on the F30 main timer, a maximum of 180 seconds. In a normal situation the bore will recover during the external timer's delay, however if the bore remains dry it is highly unlikely that the short and infrequent run time of the F30 will cause any damage to the bore pump, and the user will become aware of the problem when he runs out of water in the tank.

Made in AUSTRALIA by **KELCO ENGINEERING**

Division of CYNCARD Pty Ltd A.B.N. 20 002 834 844

Head Office and Factory: 9/9 Powells Road BROOKVALE 2100 AUSTRALIA

Postal Address PO Box 496 BROOKVALE NSW 2100

Phone: 61 2 99056425 Fax: 61 2 99056420 Email: sales@kelco.com.au URL: www.kelco.com.au

PLEASE NOTE Cyncard Pty Ltd reserves the right to change the specification of this product without notice. Cyncard Pty Ltd accepts no liability for personal injury or economic loss as a consequence of the use of this product. All rights reserved copyright Cyncard Pty Ltd C 2003